

FRENCH

F I T N E S S

FF-UBE100

French Fitness UBE100 Upper Body Ergometer Arm Bike

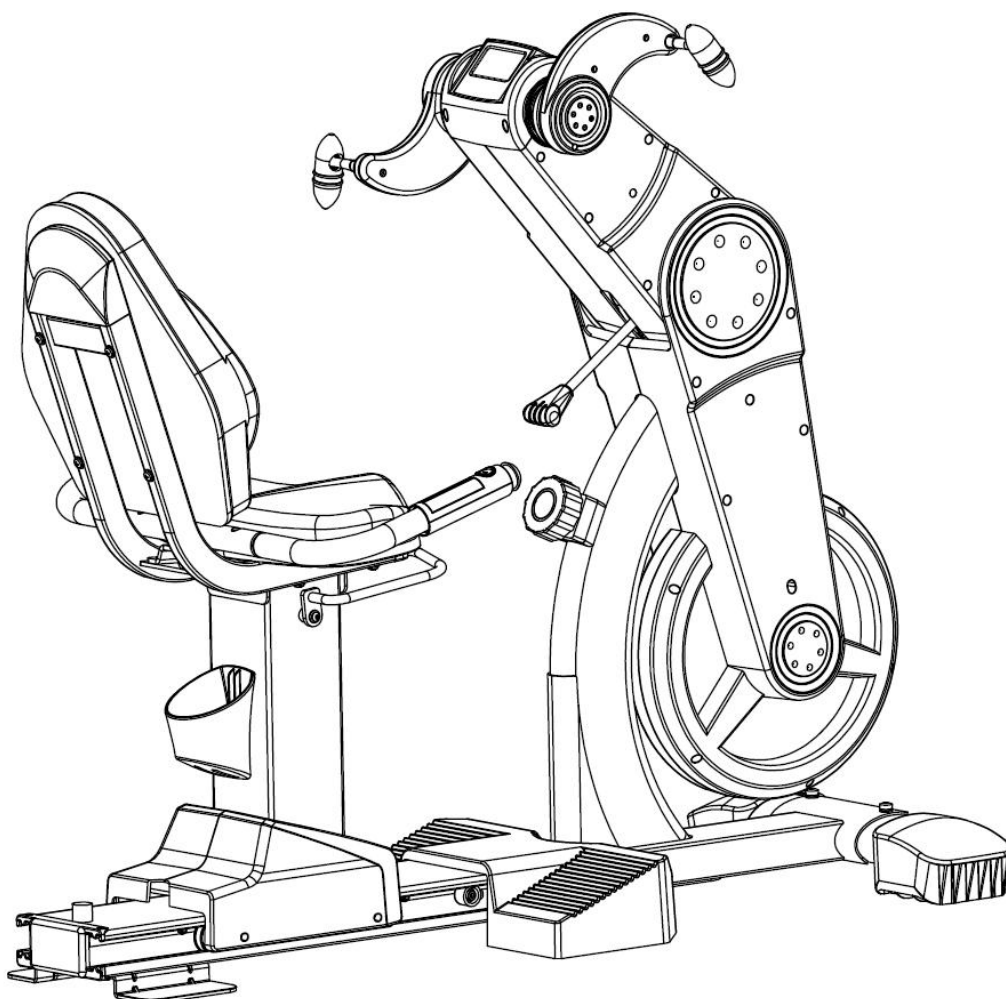

IMPORTANT !

Please read all instructions carefully before using this product.

Retain this manual for future reference.

The specifications of this product may vary slightly from the illustrations and are subject to change without notice.

SAFETY & MAINTENANCE INSTRUCTION

- 01- Once fully assembled, please check that all hardware parts such as bolts, nuts and washers are positioned and secured firmly.
- 02- Please check regularly that the safety chain guard that protects the moving parts of the machine is secured and in good order.
- 03- Please always check the seat post, seat slider; pedals and handlebar are secured firmly before getting on the bike.
- 04- To lubricate all moving parts annually is recommended.
- 05- Do not wear loose clothing to avoid entangling in any moving parts.
- 06- Do not remove feet from the pedals while they are in motion.
- 07- Always wear shoes when using the machine.
- 08- Dry the bike after each use to remove sweat and moisture. Wipe the machine with a damp cloth, water and mild soap. Do not use a petroleum-based solvent to clean the machine in order not to damage the finish.
- 09- Please keep children away from the bike while it is in use. Do not allow children to use the bike. This bike is designed for adults, not children.
- 10- Do not dismount the bike until the pedals have stopped completely.
- 11- Stop exercise immediately in case of nausea, shortness of breath, faint, headache, pain, tightness in your chest or any discomfort.
- 12- Do not place fingers or any other objects into the moving parts of the bike.
- 13- Prior to any exercise, consult with your physician first to establish the exercise frequency, time and intensity appropriate for your particular age and condition.
- 14- After exercising, please pull down the tension controller to increase resistance so that the pedals will not rotate freely and possibly hurt someone.
- 15- The maximum user's weight is 150kg

EXPLODED VIEW

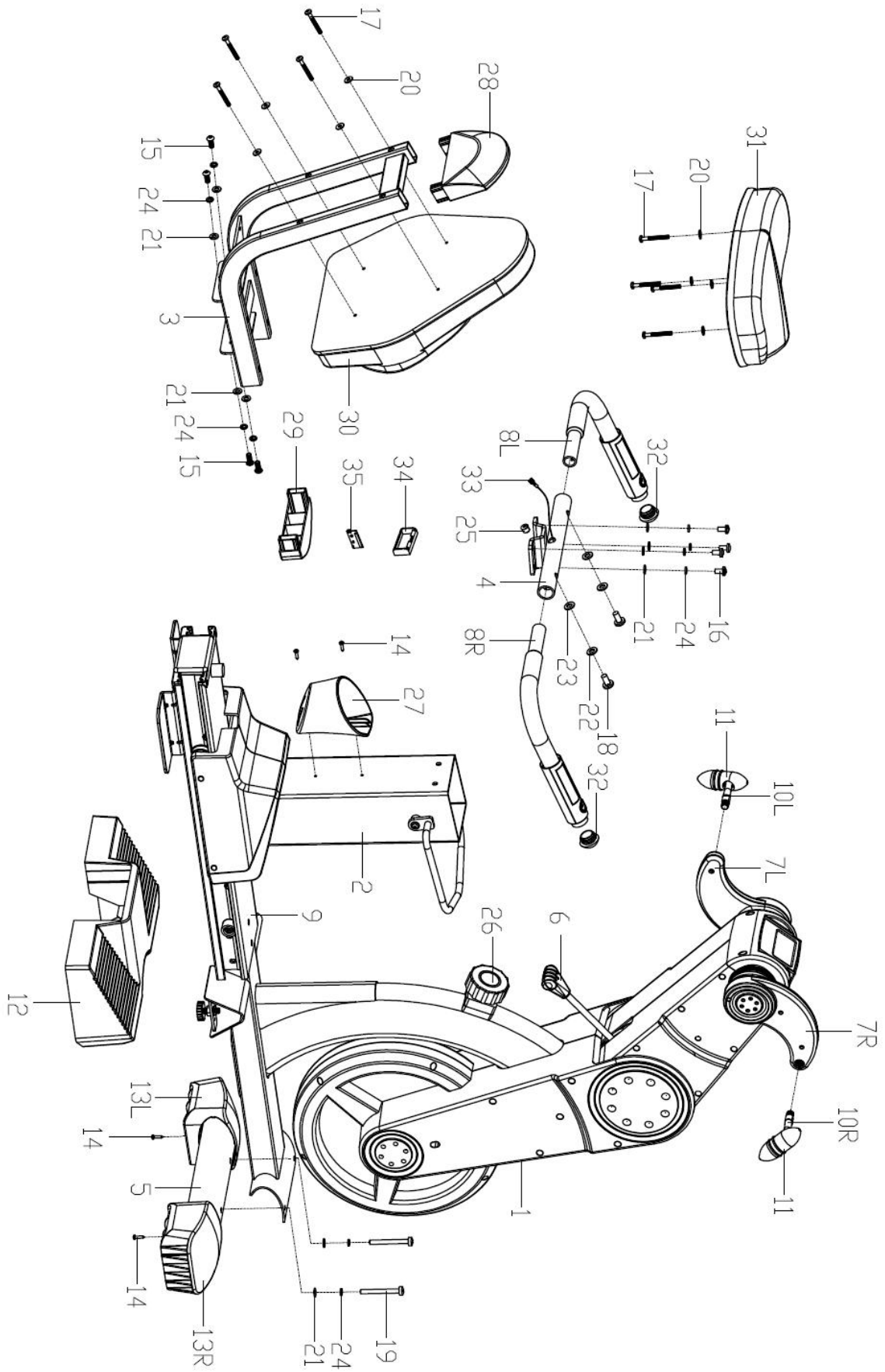

PARTS LIST

NO.	Description	QTY	NO.	Description	QTY
1	Front frame	1	19	Allen bolt M8x75xL20	2
2	Rear frame	1	20	Flat washer D16xd6x1.2	8
3	Seat combination	1	21	Flat washer D16xd6x1.5	10
4	Handlebar combination	1	22	Flat washer D10xD20x2	2
5	Front bottom tube	1	23	Nylon washer D10.8xD20x2	2
6	Adjustable knob	1	24	Spring washer D8	10
7L/R	Crank handle	1/1	25	Plug	1
8L/R	Handrail combination	1/1	26	Tension controller	1
9	Guide rail	1	27	Kettle holder	1
10L/R	Connected axle	1/1	28	Cover of back pad 2	1
11	Handle	2	29	Cover of back pad 1	1
12	Board	1	30	Back pad	1
13L/R	End cap	1/1	31	Seat	1
14	Screw ST4.2x18	4	32	Round bushing	2
15	Allen bolt M8x20	4	33	Pulse wire	1
16	Allen bolt M8x16	4	34	Battery case	1
17	Screw M6xL52	8	35	Heart rate transmitter	1
18	Allen bolt M10x20	2			

Note: Some of the above accessories are pre-fitted to the master component. They may not be supplied separately.

ASSEMBLY

Prepare the Work Area

It is important that you assemble your product in a clean, clear, uncluttered area. This will enable you to move around the product while you are fitting components and will reduce the possibility of injury during assembly.

Work with a Friend

You may find it quicker, safer and easier to assemble this product with the help of a friend as some of the components may be large, heavy or awkward to handle alone.

Open the Carton

Carefully open the carton that contains your product. Be sure to open the carton the right way up, as this will be the easiest and safest way to remove all the components.

Unpack the Components

Carefully unpack each component, checking against the parts list that you have all the necessary parts to complete the assembly of your product.

Step 2:

A: Lock the handlebar combination (4) to the seat combination (3) with Allen bolt (16), spring washer (24) and flat washer (21) tightly, then connect the pulse wire (33) with the heart rate transmitter (35) which in the cover of back pad 1 (29), then insert the cover of back pad 1 (29) into the seat combination (3).

B: Lock the seat (31) and back pad (30) to the seat combination (3) with Screw (17) and Flat washer (20) together.

C: Install the cover of back pad 2 (28) to the seat combination (3).

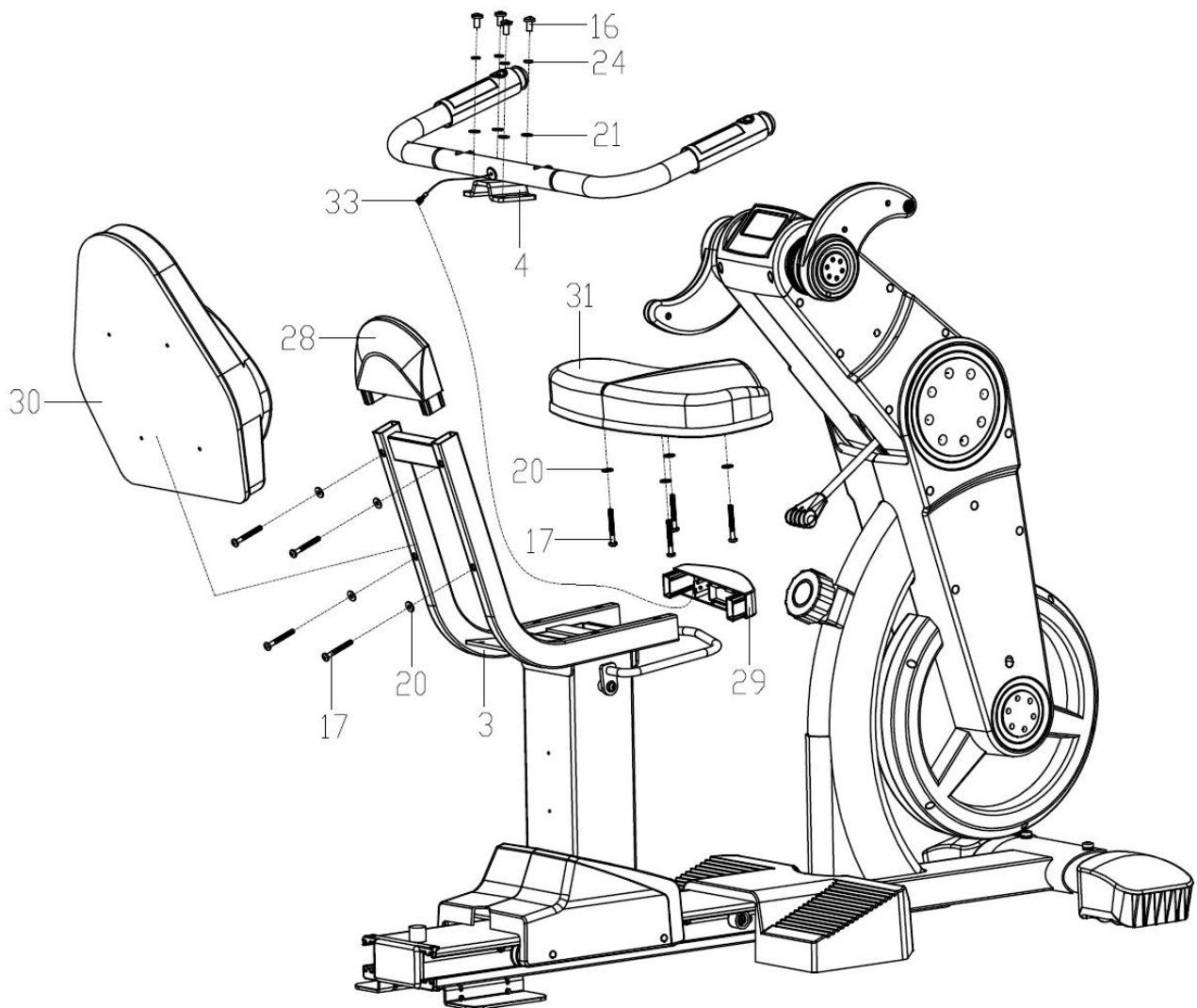

Step 3:

A: Lock the Connected axle (10L/R) to the Crank handle (7L/R) respectively.

Note: Connected axle (10L) should be tightened in anticlockwise and the Connected axle (10R) should be clockwise. Just like the arrow shown, make ensure the Connected axle (10L/R) are securely locked during exercise.

B: Lock the Kettle holder (27) on to the Rear frame (2) tightly with Screw (14).

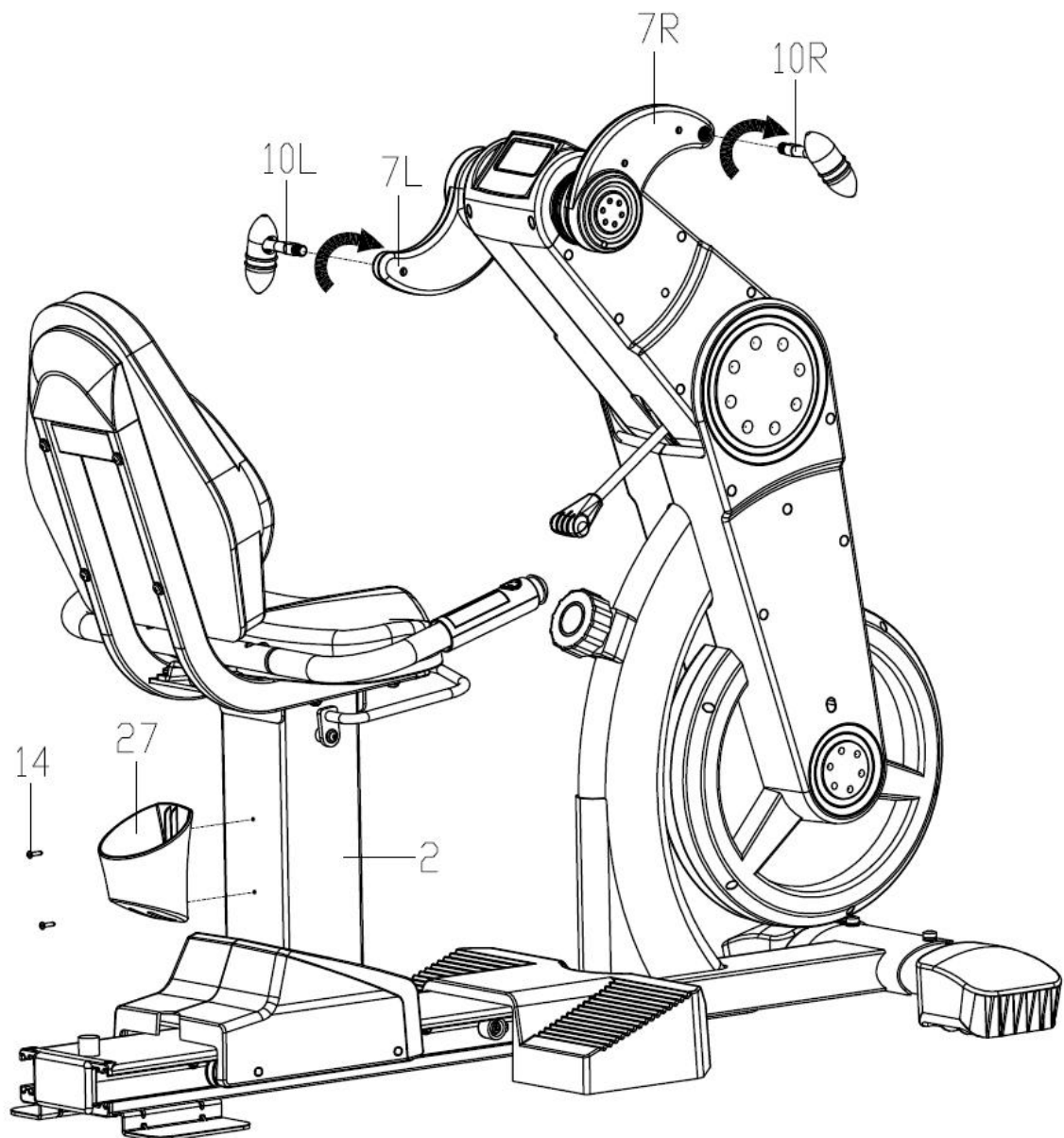

Battery placement step 1:

Gently press the clip A down, then take the cover B out, then put the batteries into the battery case like the picture C shown, then put the cover B back.

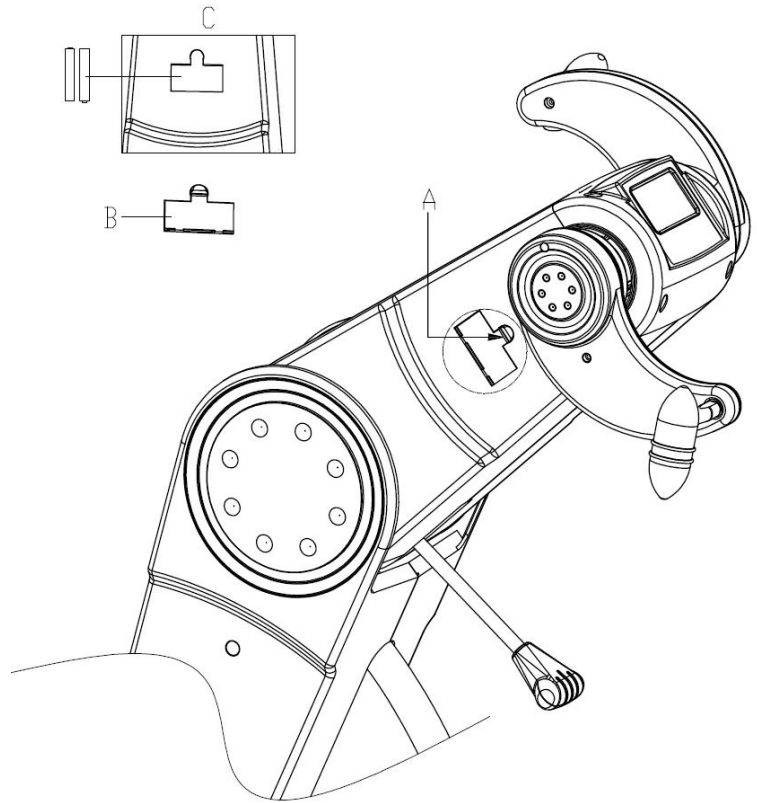

Battery placement step 2:

Remove the seat (31) firstly, then put the batteries into the position E which in the Cover of back pad 1 (29), then install the seat (31) back.

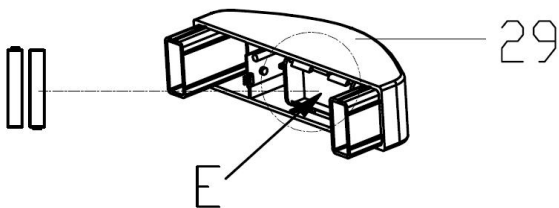
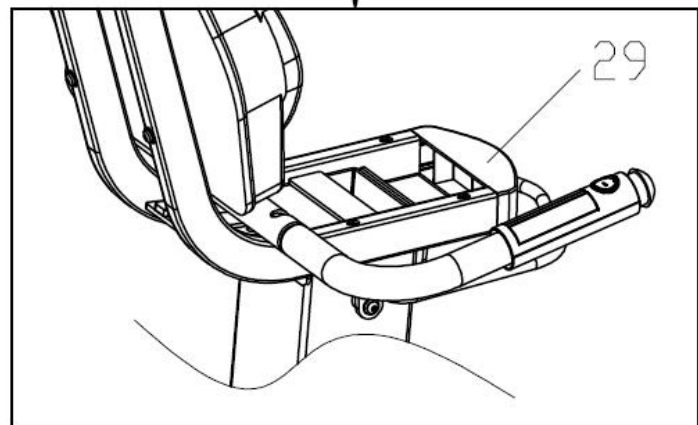
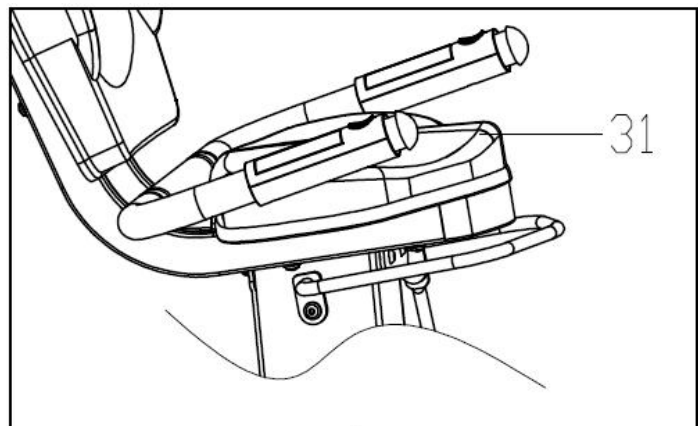

MONITOR WITH BODYFAT&PULSE RECOVERY INSTRUCTION MANUAL

🕒BUTTONS

1. MODE

Press this button to changeover display or choose the window needs to be set.

2. RECOVERY / UP

- i. In setting status, press this button to increase setting value in relevant flashing window for TIME, DIST, CAL and TEMP(°C or °F)
- ii. In non-exercise or non-setting status, press this button to enter/exit pulse recovery function.

3. DOWN

In setting status, press this button to decrease setting value in relevant flashing window for TIME, DIST, CAL and TEMP(°C or °F)

4. RESET/GO

- i. In setting status, press this button to reset the value in relevant flashing window for TIME, DIST and CAL.
- ii. In parameters setting status for body fat, press this button to enter body fat test.
- iii. In monitor status, hold this button for 3 seconds to reset all value to zero.

5. BODYFAT

In non-exercise status, press this button to enter/exit body fat parameters set-up.

🕒FUNCTIONS

1. SPEED/BODYFAT RATIO

- i. Display instantaneous speed and the range is 0.0~99.9KM/H.
- ii. Display Body fat ratio.

2. TIME/BMI

- i. Count the total time from exercise start to the end and the range is 0 ~ 99M59S.
- ii. Exercise time can be set in advance, when it approaches the preset time, the monitor will alarm 10 seconds. The maximum pre-set time is 99 minutes.
- iii. Display Body Mass Index (BMI).

3. DISTANCE/BMR

- i. Count the total distance from exercise start to the end and the range is 0.00 ~ 9.99 ~ 99.9KM.
- ii. Exercise distance can be set in advance, when it approaches the preset distance, the monitor will alarm 10 seconds. The maximum pre-set distance is 99.9KM .
- iii. Display Basal Metabolic Rate(BMR)

4. CALORIES/TEMPERATURE

- i. Count the total calories consumed from exercise start to the end and the range is 0.0 ~ 99.9 ~ 999KCAL.
- ii. The calorie value can be set in advance, when it approaches the preset calorie, the monitor will alarm 10 seconds.
- iii. Display room temperature(TEMP).

5. PULSE

- i. Hold the pulse sensor and read your heart rate per minute. The range is 40 ~ 240bpm.

6. ALARM

The monitor will “Beep” when press “MODE” “RECOVERY/UP” “DOWN”, “RESET/GO” or “BODYFAT” buttons.

7. AUTO ON/OFF & AUTO START/STOP

- i. **Without any signal of exercise or operation for 8 minutes, the power will turn off automatically and all the memory will be cleared off except body fat parameters and temperature.**
- ii. **Once receive exercise or operation signal, the monitor will turn on automatically.**

OPERATION

1. SET

Press MODE to choose the display window that needs to be pre-set, and the value in relevant window will flash. Then press UP/DOWN to increase/decrease the value to reach your want alarm time, alarm distance, or alarm calorie. Hold UP/DOWN to increase/decrease the value rapidly. Press RESET to reset value in relevant flashing window.

2. PULSE RATE

Then enter pulse mode. Please place both your palms on the contact pads and the monitor will show your current heart beat rate in beats per minute (BPM) on the LCD after 3~4 seconds.

Remark: During the process of pulse measurement, because of the contact jamming, the measurement value may be higher than the virtual pulse rate during the first 2 ~ 3 seconds, then will return to normal level. The measurement value cannot be regarded as the basis of medical treatment.

3. PULSE RECOVERY

In non-setting and non-exercising status, first test your pulse as above mentioned. Then press RECOVERY/UP to enter pulse recovery function. The display will show 1 minute count-down as well as your pulse rate. Hold on the pulse sensor until it counts down to zero. Then, it will pop up your pulse recovery level from F1 to F6, that is, from the fastest recovery to slowest. The fastest recovery F1 show the best. Press RECOVERY/UP again to exit pulse recovery function.

4. BODYFAT, BMI & BMR

In non-exercising status, press BODYFAT to enter body fat parameters settings. You can set from the below sequence: exerciser No.(1 ~ 8), weight(KG), height(CM), age (YEAR), gender. Press MODE to proceed to next parameter setting. Press RECOVERY/UP to increase the setting value while press DOWN to decrease.

When you finish setting, hold the pulse sensor and press RESET/GO. Then the display will show your body fat in 6 seconds.

Press BODYFAT again to exit body fat test.

Remark:

- i. During parameters setting, it will exit body fat test automatically if detects no operation signal over 10 seconds.
- ii. During body fat test, it will display Er.1 if sense no test target over 10 seconds.

BODYFAT CONTRAST

Gender/Age	Underweight	Healthy	Slightly Overweight	Overweight	Obese
Male/ ≤ 30	< 14%	14%~20%	20.1%~25%	25.1%~35%	> 35%
Male/ > 30	< 17%	17%~23%	23.1%~28%	28.1%~38%	> 38%
Female/≤ 30	< 17%	17%~24%	24.1%~30%	30.1%~40%	> 40%
Female/ > 30	< 20%	20%~27%	27.1%~33%	33.1%~43%	> 43%

BATTERY REPLACE

When the display becomes dim or illegible, remove the battery and replace with SIZE AAA UM4 R03.

USING YOUR BIKE

Using your spinning bike will provide you with several benefits. It will improve your physical fitness, tone your muscles and in conjunction with a calorie controlled diet, help you lose weight.

WARM-UP PHASE

The purpose of warming up is to prepare your body for exercise and to minimize injuries. Warm up for two to five minutes before strength-training or aerobic exercising. Perform activities that raise your heart rate and warm the working muscles. Activities may include brisk walking, jogging, jumping jacks, jump rope, and running in place.

STRETCHING

Stretching while your muscles are warm after a proper warm-up and again after your strength or aerobic training session is very important. Muscles stretch more easily at these times because of their elevated temperature, which greatly reduces the risk of injury. Stretches should be held for 15 to 30 seconds. DO NOT BOUNCE.

Remember always to check with your physician before starting any exercise program.

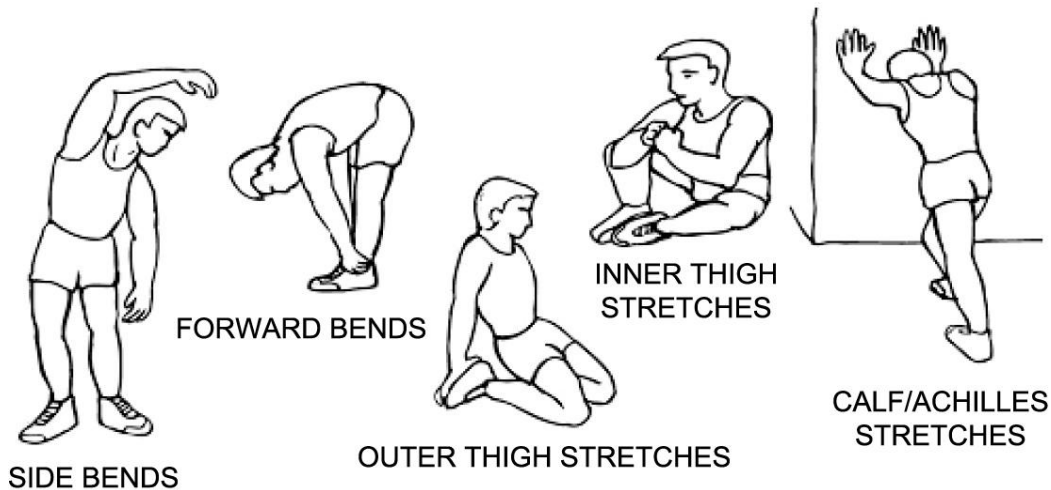

EXERCISE PHASE

This is the stage where you put the effort in. After regular use, the muscles in your legs will become more flexible. Work at your own pace and be sure to maintain a steady tempo throughout. The rate of work should be sufficient to raise your heartbeat into the target zone shown on the graph below.

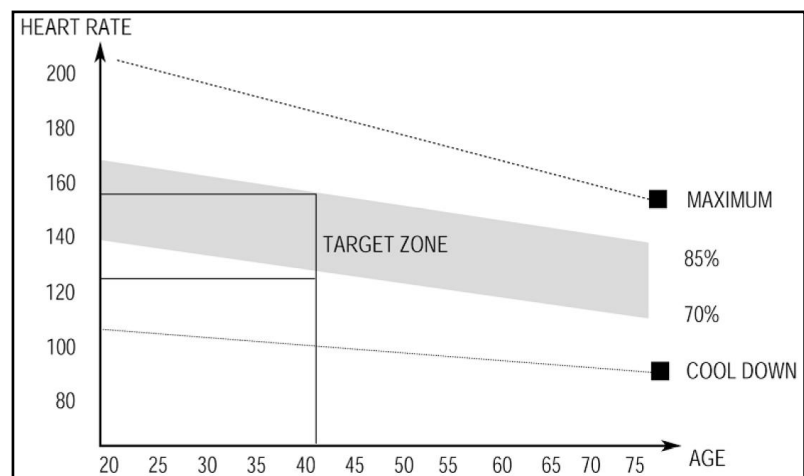

COOL-DOWN PHASE

The purpose of cooling down is to return the body to its normal or near normal, resting state at the end of each exercise session. A proper cool-down slowly lowers your heart rate and allows blood to return to the heart.